



- Locate work piece centre - simple method of centering a work piece, fixture or assembly
- Find the centre on internal or external diameters and centre point marks
- Indicator dial always faces the operator
- Hand or motor spindle driven
- Included with the centering indicator - main body with indicator dial, 3 straight feelers, 3 curved feelers, center locating feeler, spanner, retaining arm and storage case

Specifications

	MS-440-000	MS-442-000
Internal Range mm (inches)	3.5-300 (0.15-12) diameter	
External Range mm (inches)	0-300 (0-12) diameter	
Type	Metric	Imperial
Resolution mm (inches)	0.01	(0.0005)
Accuracy mm	0.01	
Maximum RPM	500	
Body Colour	Black	Silver
Spindle Diameter	10mm	3/8"

Applications

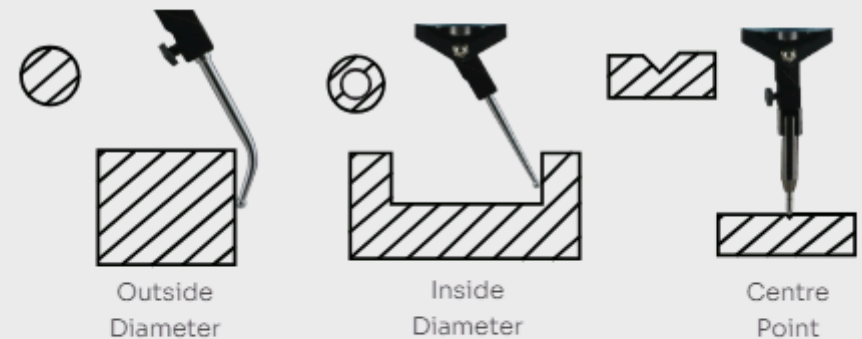

Dimensions

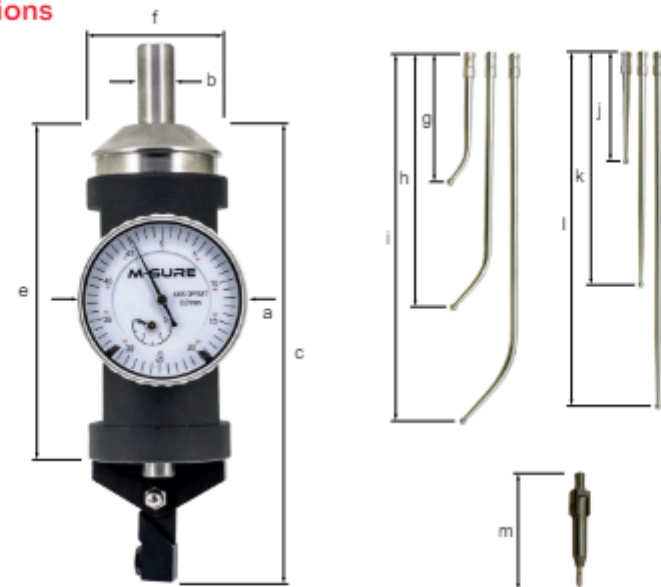

All dimensions in mm

	a	b	c	e	f	g	h	i	j	k	l	m
MS-440-000	42	10	118	86	37	50	102	153	51	102	152	51
MS-442-000		9.5										